

TECHNICAL CHARACTERISTICS

HF 710 filter series are connected to the pressure line of the circuit and protect the system's components against contaminant particles.

The standard filters are supplied with by-pass valve set at 87 psi (6 bar).

For applications which need maximum system's protection, such as servo drives or proportional controls, the filters are equipped with highly resistant filtering elements ("HC" versions) without by-pass valve, but they need the use of a clogging indicator.

- Maximum total weight 2.65 lbs (1,2 Kg)
- Aluminum head and bowl
- Maximum working pressure 3626 psi (250 bar)

MATERIALS	
Head	Anodized aluminum
Bowl	Anodized aluminum
Seals	Buna - Viton
End cap	Zinc plated steel
Inner tube	Zinc plated steel
Filter media	Inorganic micro-fibre glass

FLUID COMPATIBILITY	
Conforming to ISO 2943 (Norm ISO 6743/4)	
Oil mineral (1)	HH - HL - HM - HR - HV - HG
Water emulsion (1)	HFAE - HFAS
Water glycol (1)	HFC
Synthetic fluid (2)	HS - HFDR - HFDU - HFDS
(1) With Buna seals	
(2) With Viton seals	

FLOW	
Flow max.	12.4 US gpm (47 l/min)

PRESSURE	
Working pressure	3626 psi (250 bar)
Testing pressure	5439 psi (375 bar)
Burst pressure	7252 psi (500 bar)
Element collapse pressure	290 psi (20 bar) (version LC)
rating (conforming to ISO 2941)	3045 psi (210 bar) (version HC)

BY-PASS VALVE	
By-pass setting	87 psi (6 bar)

OPERATING TEMPERATURE	
With Buna seals	-30 ÷ 90 °C
With Viton seals	-20 ÷ 110 °C

ENDURANCE STRENGTH	
1.000.000 cycle	
0 ÷ 3626 psi (0 ÷ 250 bar)	

DEGREE OF FILTRATION			
Multi-pass test conforming to ISO 16889 (regulation in force) Contaminant ISO MTD - final Δp 87 psi (6 bar)			
Code	Degree of filtration	Ratio $\beta_{x(c)}$	Percentage of efficiency
FG003	5 μm	$\beta_{5(c)} \geq 200$	99,5 %
FG006	7 μm	$\beta_{7(c)} \geq 200$	99,5 %
FG010	10 μm	$\beta_{10(c)} \geq 200$	99,5 %
FG025	21 μm	$\beta_{21(c)} \geq 200$	99,5 %

Multi-pass test conforming to ISO 4572 (previous regulation) Contaminant ACFTD - final Δp 87 psi (6 bar)			
Code	Degree of filtration	Ratio β_x	Percentage of efficiency
FG003	3 μm	$\beta_3 \geq 200$	99,5 %
FG006	6 μm	$\beta_6 \geq 200$	99,5 %
FG010	10 μm	$\beta_{10} \geq 200$	99,5 %
FG025	25 μm	$\beta_{25} \geq 200$	99,5 %

INDICATORS	
Visual differential indicator	
Visual electrical differential indicator	
Visual electrical differential indicator with thermostat	

01/02.2011

HF710-10 DIMENSIONS

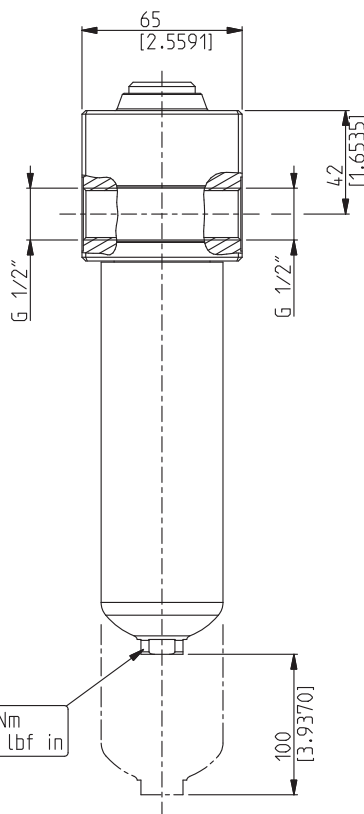
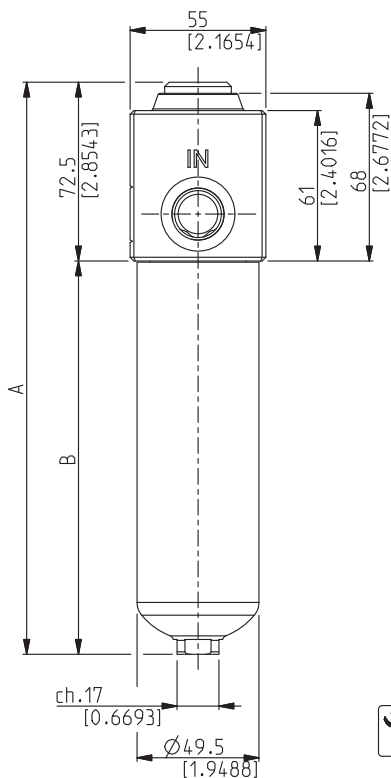

With plug "G"

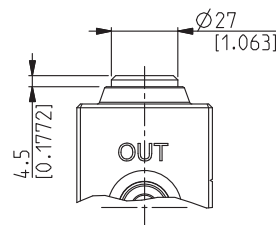

With indicator "H"

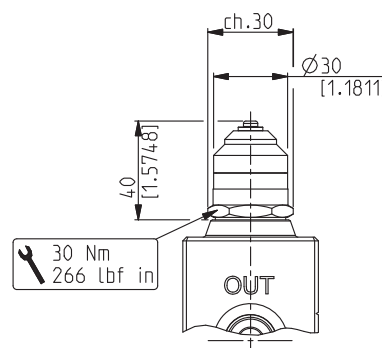

Elements HE K85-10

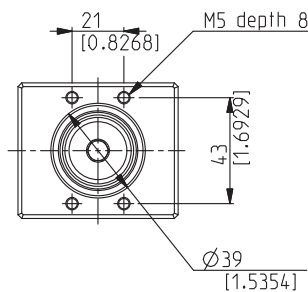
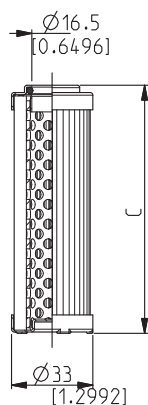

With indicators "U" o "W"

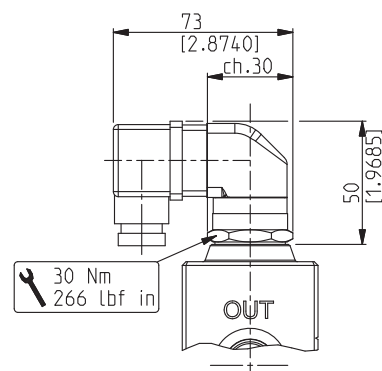

01/02.2011
ICAT_017_002_HF710

Filter type	Weight		A		B	
	kg	(lbs)	mm	(in)	mm	(in)
HF 710-10.050	1,0	(2.20)	182	(7.1653)	109.5	(4.3110)
HF 710-10.100	1,2	(2.65)	232	(9.1338)	159.5	(6.2795)

Element type	C	Filtering surface	Dirt holding capacity (ISO MTD) $\Delta p = 72.5$ psi (5 bar)			
			FG003	FG006	FG010	FG025
	mm (in)	cm ² (in ²)	gr (lbs)	gr (lbs)	gr (lbs)	gr (lbs)
HE K85-10.050	50 (1.9685)	162 (25.1100)	0,9 (0.0020)	1,2 (0.0026)	1,3 (0.0029)	1,9 (0.0042)
HE K85-10.100	100 (3.9370)	342 (53.0101)	1,9 (0.0042)	2,5 (0.0055)	2,7 (0.0060)	4,0 (0.0088)

COMPLETE FILTER'S PRESSURE DROP

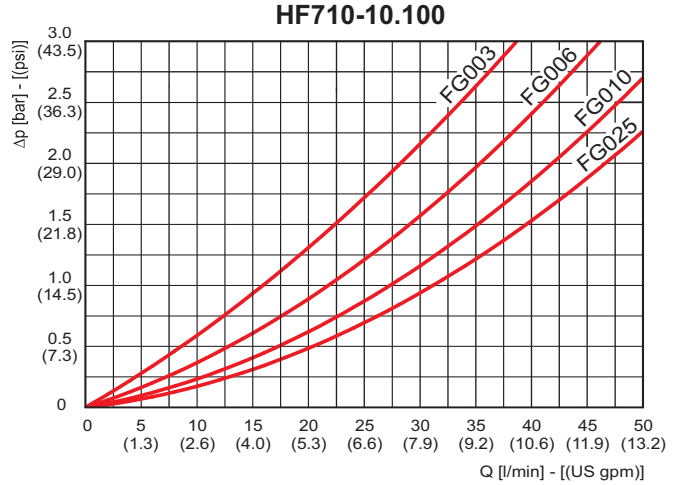
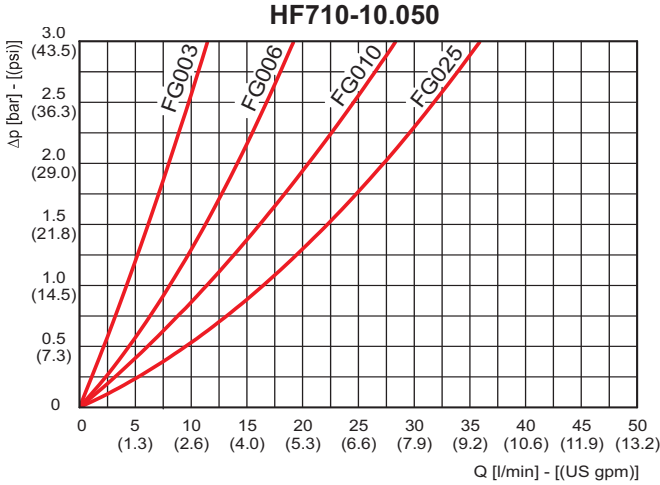

The curves are obtained in the following conditions: mineral oil type SAE 10, kinematic viscosity 120 SSU (30 cSt), density 7.29 lb/gal (0,856 kg/dm³).

FLOW

Filter type	Degree of filtration			
	FG003	FG006	FG010	FG025
	Flow Δp= 29 psi (2 bar) US gpm (l/min)			
HF 710-10.050	2.1 (8)	3.7 (14)	5.5 (21)	7.1 (27)
HF 710-10.100	7.4 (28)	9.5 (36)	11.1 (42)	12.4 (47)

HOW TO ORDER A COMPLETE FILTER

1	2	3	4	5	6	7	8	9
HF710 - 10.100 - AS - FG010 - LC - B60 - GD - B - XD - G								
1 Filter type CODE See table pag. 2 HF710-	2 Filtering surface CODE Standard AS	3 Degree of filtration CODE 3 [μm] Micro-fibre glass FG003 6 [μm] Micro-fibre glass FG006 10 [μm] Micro-fibre glass FG010 25 [μm] Micro-fibre glass FG025	4 Δp collapse pressure CODE 290 [psi] (20 [bar]) LC 3046 [psi] (210 [bar]) HC	5 By-pass valve CODE With By-pass setting valve 87 [psi] (6 [bar]) B60 Without B00	6 Ports IN/OUT CODE Threads GAS (BSPP) G 1/2 GD	7 Seals CODE Buna B Viton V	8 Indicator arrangement CODE Upper side arranged XD	9 Indicators CODE Without indicator, with plug G Visual differential indicator H Visual electrical differential indicator U Visual electrical differential indicator with thermostat W

Standard On request

HOW TO ORDER A REPLACEMENT ELEMENT

1	2	3	4	5
HE K85 10.100 - AS - FG010 - LC - B				
1 Filter type CODE See table pag. 2 HE K85-	2 Filtering surface CODE Standard AS	3 Degree of filtration CODE 3 [μm] Micro-fibre glass FG003 6 [μm] Micro-fibre glass FG006 10 [μm] Micro-fibre glass FG010 25 [μm] Micro-fibre glass FG025	4 Δp collapse pressure CODE 290 [psi] (20 [bar]) LC 3046 [psi] (210 [bar]) HC	5 Seals CODE Buna B Viton V

Edition: 01/02.2011
HF 710 01 TA