

TECHNICAL CHARACTERISTICS

The filters of the HF735 series are connected to the pressure line of the circuit and they protect the system's components against contaminant particles.

The standard filters are supplied with by-pass valve calibrated at 87 psi (6 bar).

For applications where the maximum protection of the system is requested, such as servo drives or proportional controls, the filters are equipped with highly resistant filtering elements (versions "HC") and do not have a by-pass valve.

- Flow up to 40 US gpm (150 l/min)
- Maximum working pressure 4640 psi (320 bar)
- High efficiency multilayer system
- Direct mounting on manifold

MATERIALS

Head	Spheroidal cast iron GS 450-10 UNI ISO 1083
Bowl	Extruded steel
Seals	Buna - Viton
End cap	Zinc plated steel
Inner tube	Zinc plated steel
Filter media	Inorganic micro-fibre glass

FLUID COMPATIBILITY

Conforming to ISO 2943 (Norm ISO 6743/4)

Oil mineral (1)	HH - HL - HM - HR - HV - HG
Water emulsion (1)	HFAE - HFAS
Water glycol (1)	HFC
Syntetic fluid (2)	HS - HFDR - HFDU - HFDS
(1) With Buna seals	
(2) With Viton seals	

FLOW

Flow max.	40 US gpm (150 l/min)
-----------	-----------------------

PRESSURE

Working pressure	4640 psi (320 bar)
Testing pressure	6960 psi (480 bar)
Burst pressure	9280 psi (640 bar)
Element collapse pressure	290 psi (20 bar) (version LC)
rating (conforming to ISO 2941)	3045 psi (210 bar) (version HC)

BY-PASS VALVE

By-pass setting	87 psi (6 bar)
-----------------	----------------

OPERATING TEMPERATURE

With Buna seals	-22 ÷ 195 °F (-30 ÷ 90 °C)
With Viton seals	-4 ÷ 230 °F (-20 ÷ 110 °C)

ENDURANCE STRENGTH

1.000.000 cycle
0 ÷ 4640 psi (0 ÷ 320 bar)

DEGREE OF FILTRATION

Multi-pass test conforming to ISO 16889 (regulation in force)
Contaminant ISO MTD - final Δp 87 psi (6 bar)

Code	Degree of filtration	Ratio $\beta_{x(c)}$	Percentage of efficiency
FG003	5 μm	$\beta_{5(c)} \geq 200$	99,5 %
FG006	7 μm	$\beta_{7(c)} \geq 200$	99,5 %
FG010	10 μm	$\beta_{10(c)} \geq 200$	99,5 %
FG025	21 μm	$\beta_{21(c)} \geq 200$	99,5 %

Multi-pass test conforming to ISO 4572. (previous regulation)
Contaminant ACFTD - final Δp 87 psi (6 bar)

Code	Degree of filtration	Ratio β_x	Percentage of efficiency
FG003	3 μm	$\beta_3 \geq 200$	99,5 %
FG006	6 μm	$\beta_6 \geq 200$	99,5 %
FG010	10 μm	$\beta_{10} \geq 200$	99,5 %
FG025	25 μm	$\beta_{25} \geq 200$	99,5 %

INDICATORS (3)

Visual differential indicator
Visual electrical differential indicator
Visual electrical differential indicator with thermostat

(3) Characteristics and dimensions pag. 11

SIZING – PRESSURE DROP

The total pressure drop of the filter is calculated by summing the pressure drop value in the housing to that in the filtering element.

Total $\Delta p = \Delta p$ in housing + Δp in element

In the filters of series HF735 in normal working conditions, the total Δp must not be more than 11 psi (0,75 bar) whereas, for use in harsh conditions, it must be within 14.5 ÷ 22 psi (1 ÷ 1,5 bar).

To establish the values of pressure drop involved, the following pages provide some diagrams with curves referred to the use of mineral oils ISO VG46 with kinematic viscosity of 120 SSU (30 cSt) and density of 7.29 lb/gal (0,856 kg/dm³).

Example calculation

Filter HF735-20.106-AS-FG010-LC-B60-GD-B-DD-G

Flow rate= 12 US gpm (45 l/min)

Kinematic viscosity: 120 SSU (30 cSt)

Oil density : 7.29 lb/gal (0,856 kg/dm³)

Filtering degree: 10 μ m

Data obtained from the diagrams:

Δp in housing = 2.00 psi (0,14 bar) (page 4)

Δp in element = 7.25 psi (0,50 bar) (page 5)

Total $\Delta p = 2.00 + 7.25 = 9.25$ psi (0,64 bar) (Δp is lower than maximum value admitted – therefore sizing is correct).

If oil with different kinematic viscosity and different density is used, the values obtained from the diagrams shall be re-calculated considering the following indications:

1) The pressure drop of the housing is proportional with the oil density, therefore for oil with density different to 7.29 lb/gal (0,856 kg/dm³) the value of the Δp in the head-bowl will be:

$$\Delta p \text{ in housing} = \frac{\Delta p \text{ of diagram (psi)} \cdot \text{Oil density (lb/gal)}}{7.29 \text{ (lb/gal)}} \quad [\text{psi}]$$

Or

$$\Delta p \text{ in housing} = \frac{\Delta p \text{ of diagram (bar)} \cdot \text{Oil density (kg/dm}^3\text{)}}{0,856 \text{ (kg/dm}^3\text{)}} \quad [\text{bar}]$$

2) The pressure drop of the element is proportional with the oil density and kinematic viscosity, therefore for oil with density different to 7.29 lb/gal (0,856 kg/dm³) and kinematic viscosity different to 120 SSU (30 cSt) the value of Δp in the element will be:

$$\Delta p \text{ element} = \Delta p \text{ of diagram (psi)} \cdot \frac{\text{Oil density (lb/gal)}}{7.29 \text{ (lb/gal)}} \cdot \frac{\text{Oil viscosity (SSU)}}{120 \text{ (SSU)}} \quad [\text{psi}]$$

Or

$$\Delta p \text{ element} = \Delta p \text{ of diagram (bar)} \cdot \frac{\text{Oil density (kg/dm}^3\text{)}}{0,856 \text{ (kg/dm}^3\text{)}} \cdot \frac{\text{Oil viscosity (cSt)}}{30 \text{ (cSt)}} \quad [\text{bar}]$$

Now you sum the values of the pressure drop of the housing to the value of the pressure drop of the filtering element, always making sure the total Δp does not exceed the pressure limit of 11 psi (0,75 bar).

03/10.2015

PRESSURE DROP CURVES THROUGH THE BY-PASS VALVES

The pressure drop values are directly proportional with the specific weight of the fluid and do not affect the establishment of the total pressure drop of the complete filter.

The curves are obtained in the following conditions:
 Mineral oil type ISO VG46
 Kinematic viscosity 120 SSU (30 cSt)
 Density 7.29 lb/gal (0,856 kg/dm³).

HF735-20

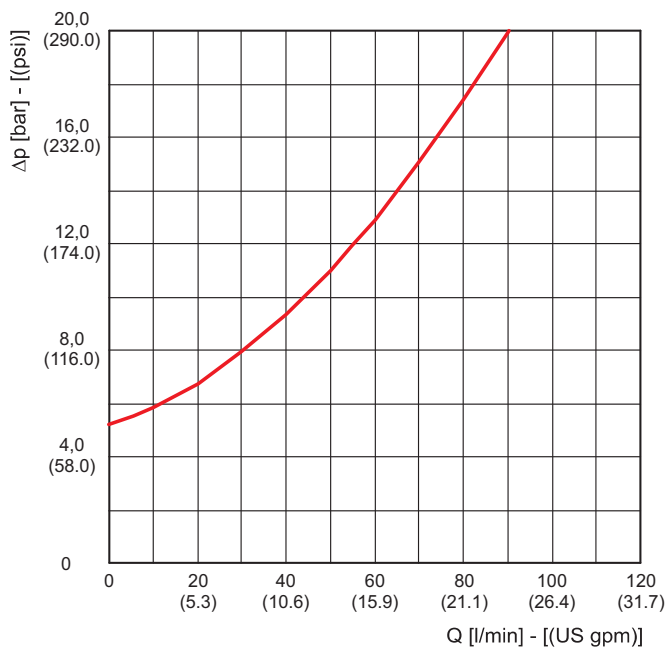

HF735-30

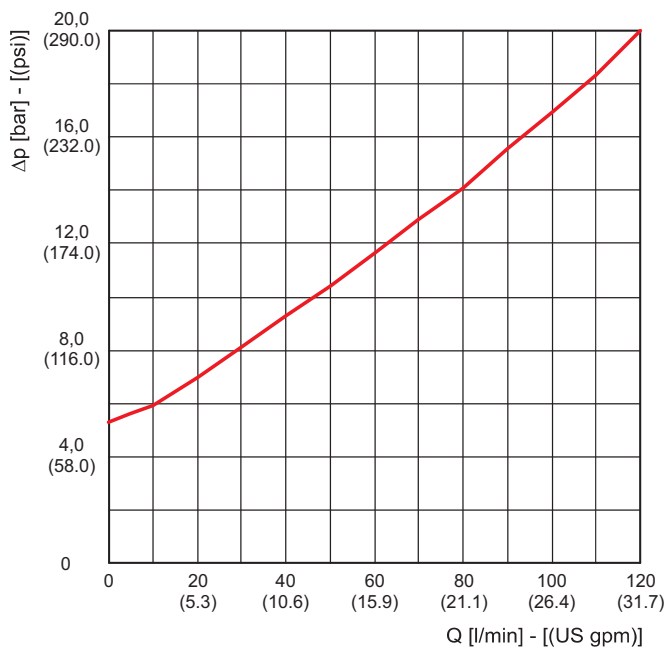

03/10.2015

PRESSURE DROP CURVES THROUGH THE HOUSING

The curves are obtained in the following conditions:
 Mineral oil type ISO VG46
 Kinematic viscosity 120 SSU (30 cSt)
 Density 7.29 lb/gal (0,856 kg/dm³).

HF 735-20

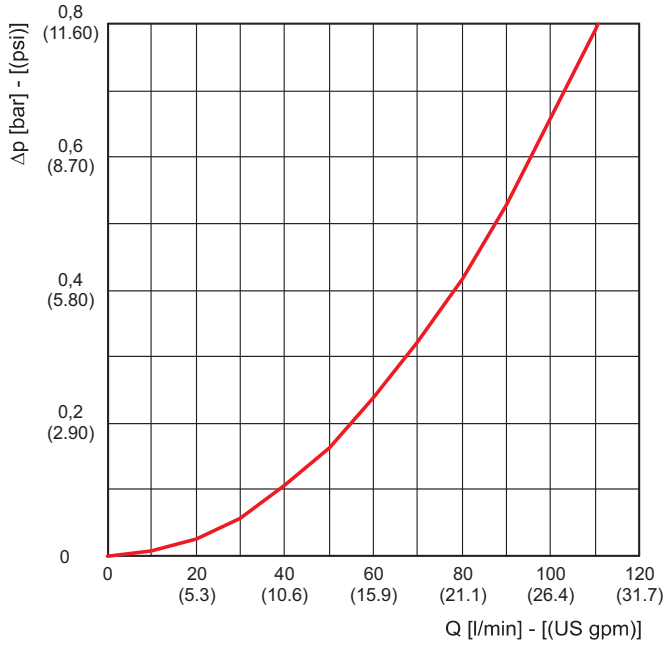

735-30

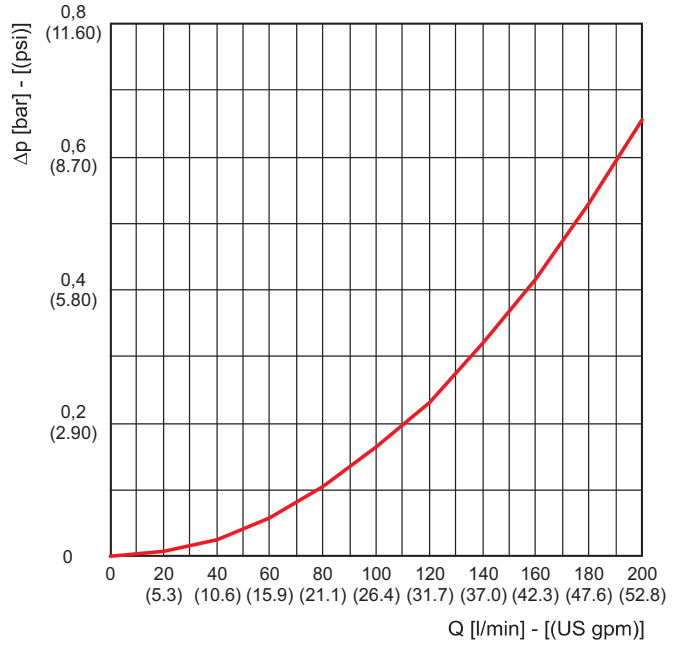

03/10.2015

PRESSURE DROP CURVES THROUGH THE ELEMENT HEK85-20

The curves are obtained in the following conditions:
 Mineral oil type ISO VG46
 Kinematic viscosity 120 SSU (30 cSt)
 Density 7.29 lb/gal (0,856 kg/dm³).

- (1) HEK85-20.080
- (2) HEK85-20.106
- (3) HEK85-20.203

FG003

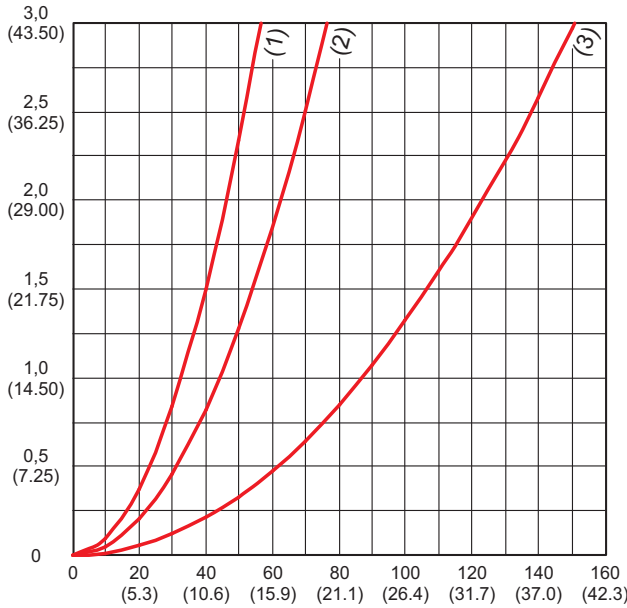

FG006

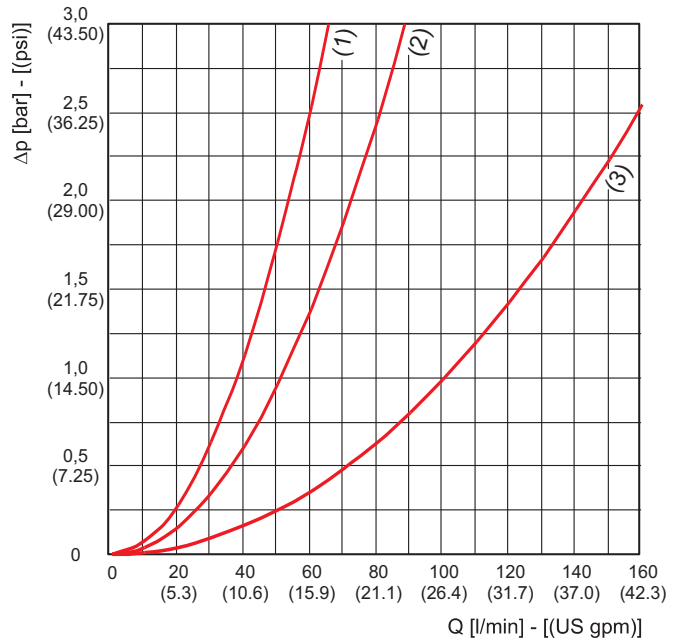

FG010

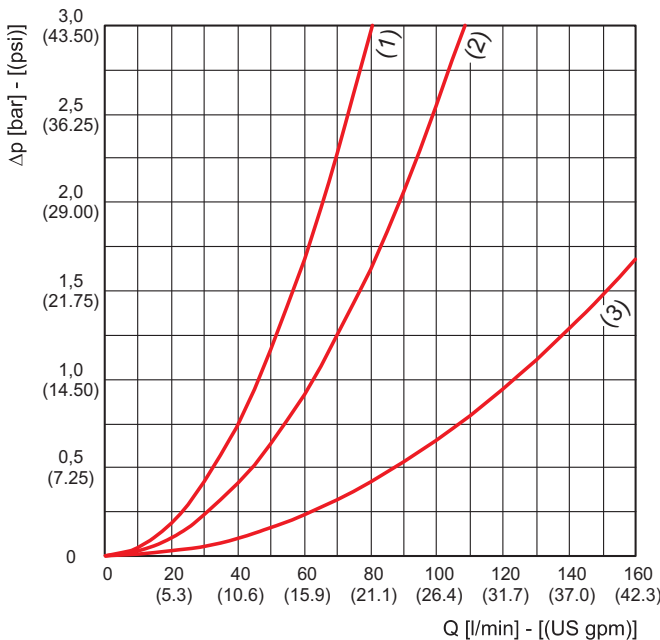

FG025

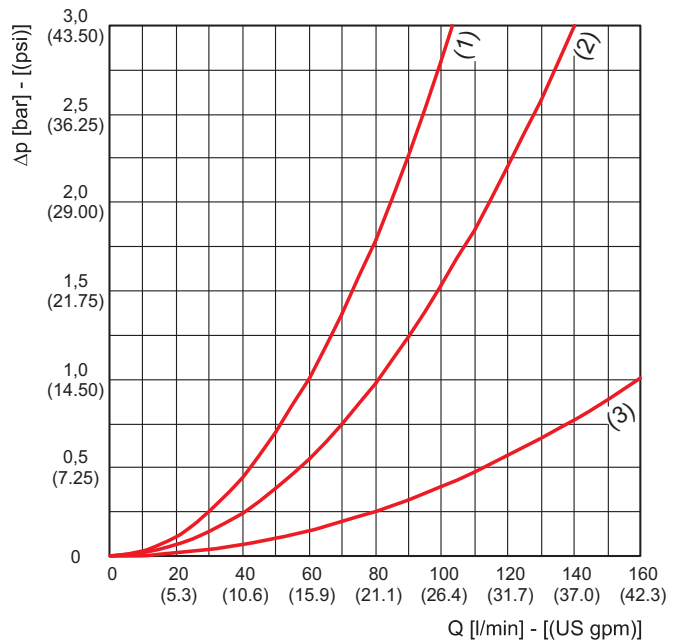

03/10.2015

PRESSURE DROP CURVES THROUGH THE ELEMENT HEK85-30

The curves are obtained in the following conditions:
 Mineral oil type ISO VG46
 Kinematic viscosity 120 SSU (30 cSt)
 Density 7.29 lb/gal (0,856 kg/dm³).

- (1) HEK85-30.115
- (2) HEK85-30.223

FG003

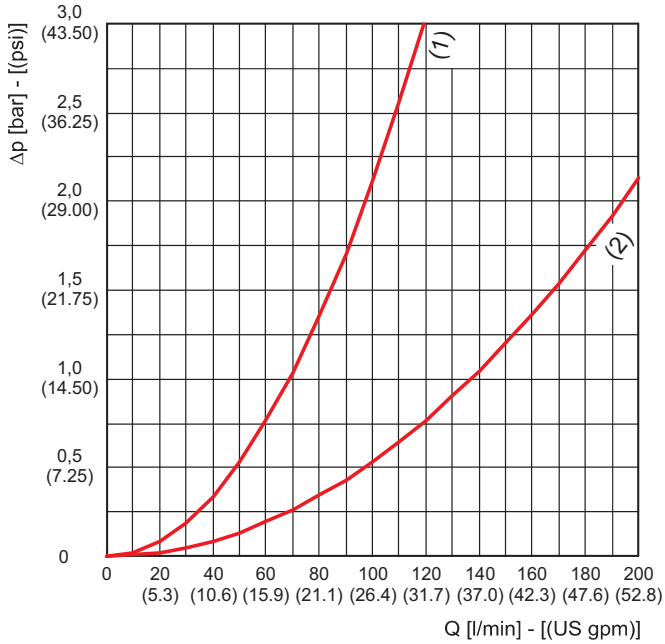

FG006

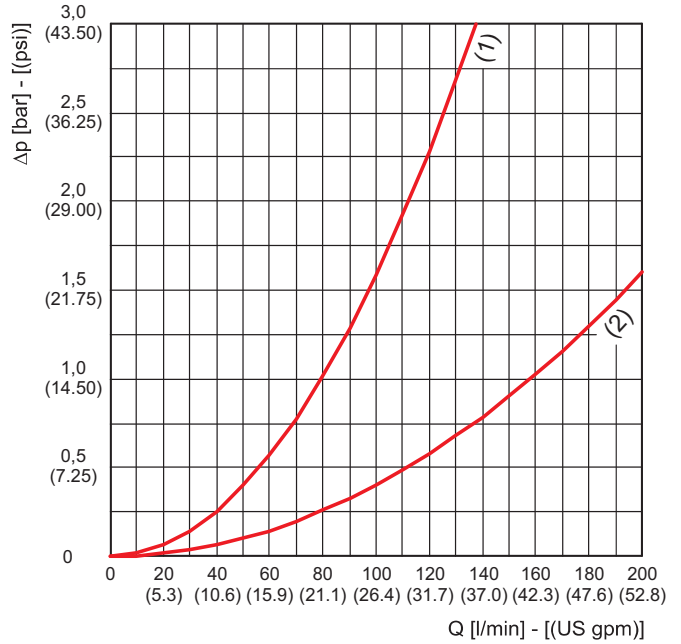

FG010

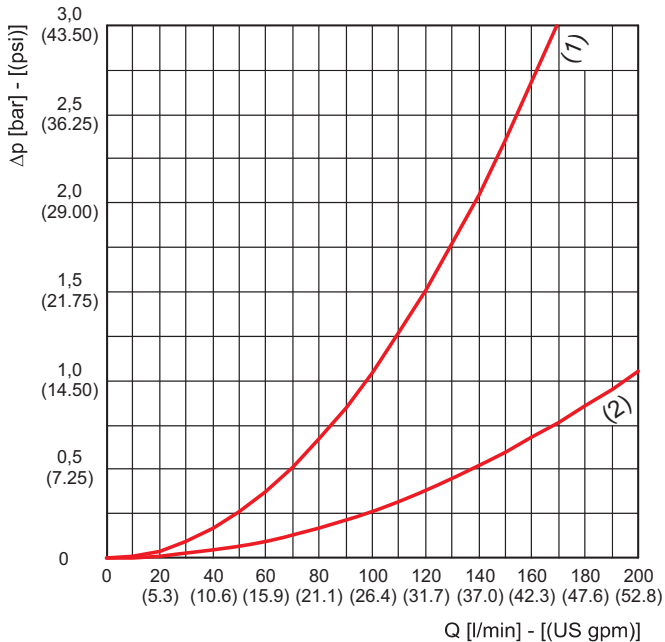

FG025

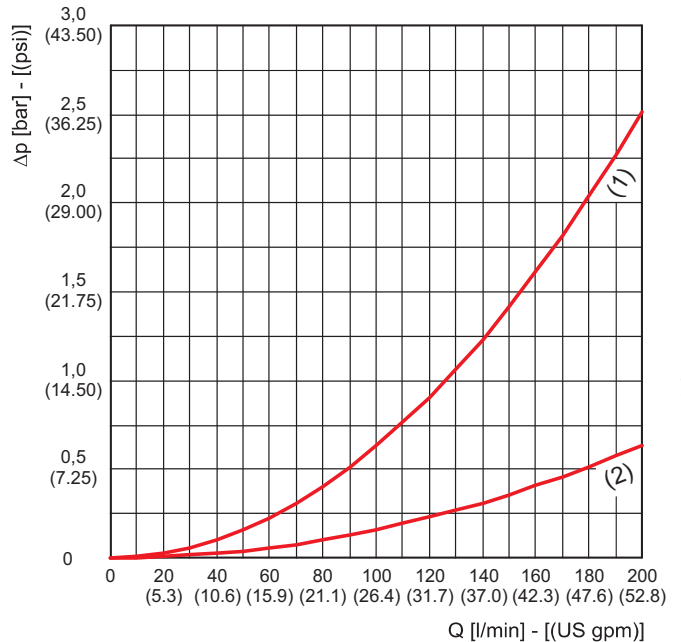

03/10.2015

FLOW

Filter type	Degree of filtration			
	FG003	FG006	FG010	FG025
	Flow Δp= 11 psi (0,75 bar) US gpm (l/min)			
HF735-20.080	6.6 (25)	7.9 (30)	9.2 (35)	11.9 (45)
HF735-20.106	7.9 (30)	10.6 (40)	11.9 (45)	15.9 (60)
HF735-20.203	13.2 (50)	14.5 (55)	15.9 (60)	21.1 (80)
HF735-30.115	15.9 (60)	18.4 (70)	22.4 (85)	29.1 (110)
HF735-30.223	27.7 (105)	31.7 (120)	35.7 (135)	39.6 (150)

03/10.2015

HF735-20 DIMENSIONS

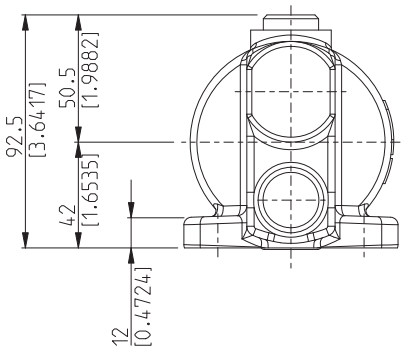
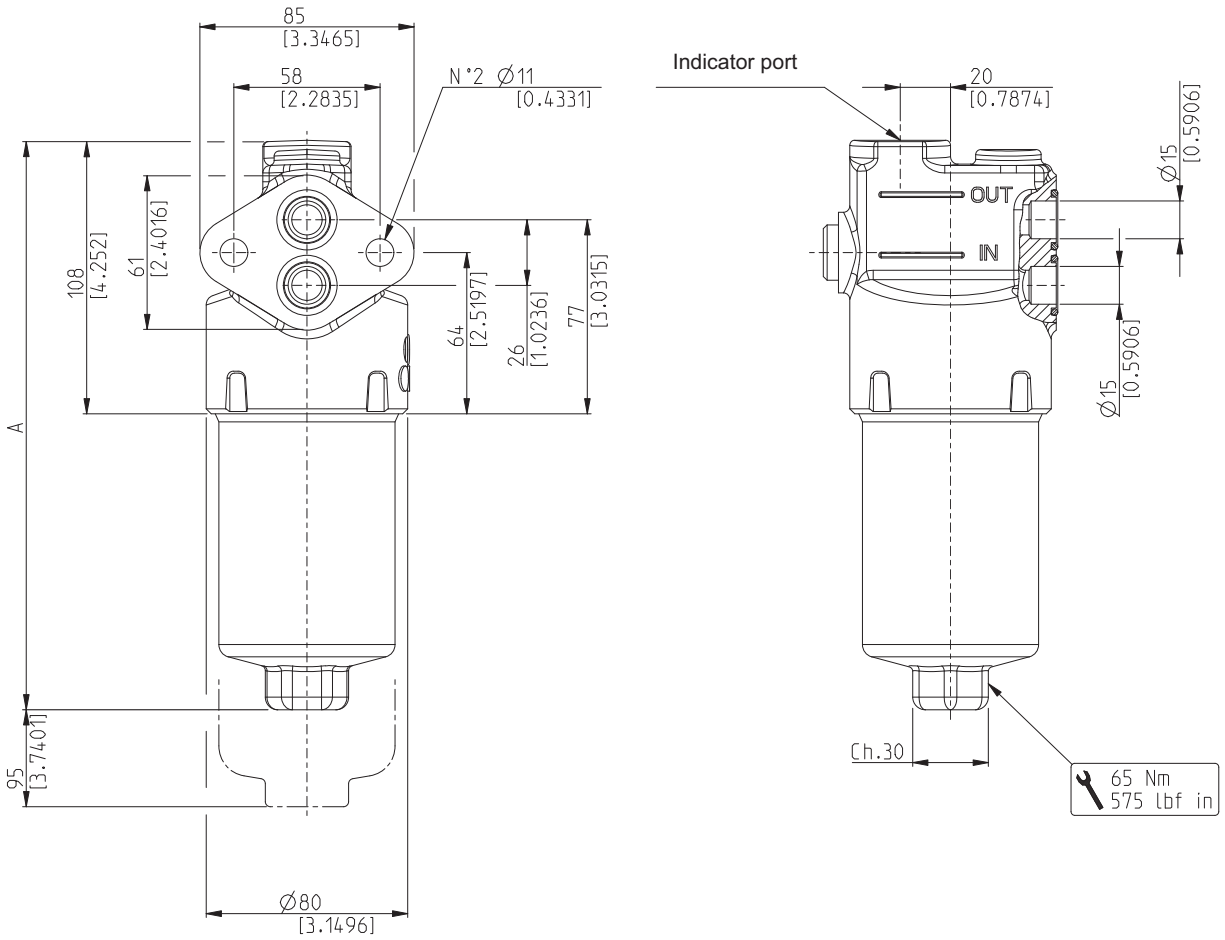

ICAT_022_001_HF735

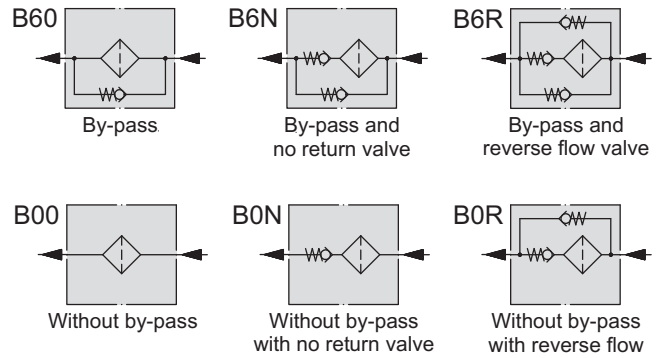

Filter type	Weight		A
	kg (lbs)		mm (in)
HF735-20.080	3,7 (8.15)		200 (7.8740)
HF735-20.106	4,1 (9.03)		226 (8.8976)
HF735-20.203	5,6 (12.34)		323 (12.7165)

03/10.2015

ELEMENTS DIMENSIONS FOR HF735

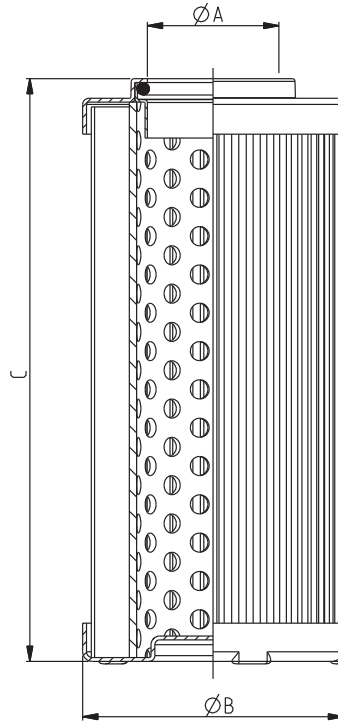

ICAT_011_004_HF760

Filtering elements with Δp - collapse pressure of 3046 psi (210 bar) are also available (please consult our technical department).

Technical data for (MS) version elements are available on request.

Element type	Ø A	Ø B	C	Filtering surface (AS)	Dirt holding capacity (ISO MTD)			
					$\Delta p = 72.5 \text{ psi (5 bar)}$			
					FG003	FG006	FG010	FG025
mm (in)	mm (in)	mm (in)	cm ² (in ²)	gr (lbs)	gr (lbs)	gr (lbs)	gr (lbs)	
HEK85-20.080			87 (3.4252)	415 (64.3251)	2,3 (0.0051)	3,0 (0.0066)	3,3 (0.0073)	4,8 (0.0106)
HEK85-20.106	25,5 (1.0039)	46,5 (1.8307)	113 (4.4488)	560 (86.8002)	3,1 (0.0069)	4,0 (0.0089)	4,5 (0.0099)	6,5 (0.0143)
HEK85-20.203			210 (8.2677)	1103 (170.9653)	6,2 (0.0136)	7,9 (0.0175)	8,8 (0.0195)	12,8 (0.0282)
HEK85-30.115	27,5 (1.0827)	54,5 (2.1457)	122 (4.8031)	908 (140.7403)	5,1 (0.0112)	6,5 (0.0144)	7,3 (0.0160)	10,5 (0.0232)
HEK85-30.223			230 (9.0551)	1808 (280.2405)	10,1 (0.0223)	13,0 (0.0287)	14,5 (0.0319)	21,0 (0.0462)

03/10.2015

INDICATORS

VISUAL DIFFERENTIAL

Code: **H**

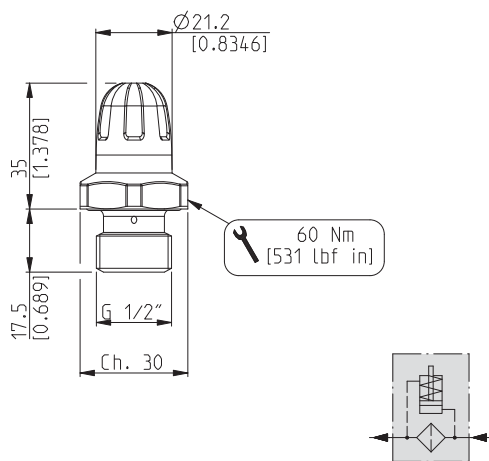

ICAT_011_006_HF760

Differential pressure setting	116 psi (8 bar) without by-pass
	72.5 psi (5 bar) with by-pass

VISUAL ELECTRICAL DIFFERENTIAL

Code: **U**

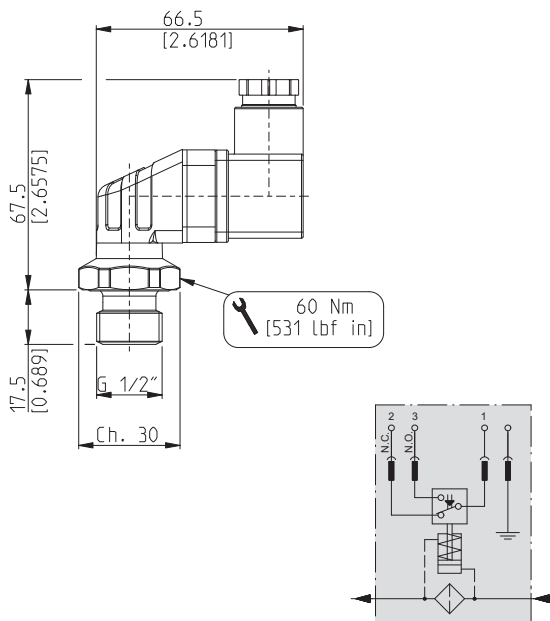

ICAT_011_007_HF760

Differential pressure setting	116 psi (8 bar) without by-pass
	72.5 psi (5 bar) with by-pass
Max. working voltage	250 VAC
	30 VCC
Max. working current	3 A (resistivity)
	3 A (inductive)
Protection class	IP 66

VISUAL ELECTRICAL DIFFERENTIAL WITH THERMOSTAT

Code: **W**

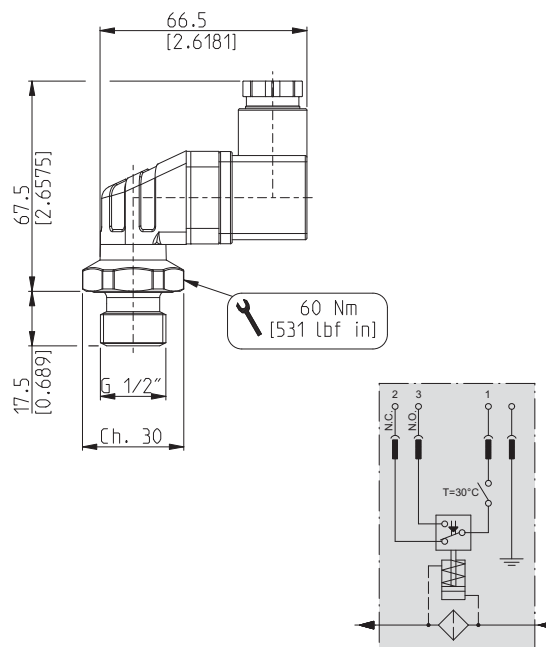

ICAT_011_011_HF760

Differential pressure setting	116 psi (8 bar) without by-pass
	72.5 psi (5 bar) with by-pass
Max. working voltage	250 VAC
	30 VCC
Max. working current	3 A (resistivity)
	3 A (inductive)
Protection class	IP 66
Min. function temperature	86 °F (30 °C)

03/10.2015

ASSEMBLY AND REPLACING ELEMENT INSTRUCTIONS

ASSEMBLY

Once you have checked the integrity of the filter inside its package, proceed as follows:

- A Take the protection caps off the oil inlet and outlet.
- B Secure the filter to the attachment device via the flange's holes of the head (pos.6), checking the flow direction, which is determined by the IN and OUT incisions.
- C If the clogging indicator (pos.9 - 10 - 11) is immediately mounted in the filter, take the protection cap off and screw the indicator in the dedicated seat, then tighten to a tightening torque of 531 lbf in (60 Nm). If the indicator is electric, complete the required connections.
- D Start the circuit for a few minutes.
- E Make sure there are no leaks.

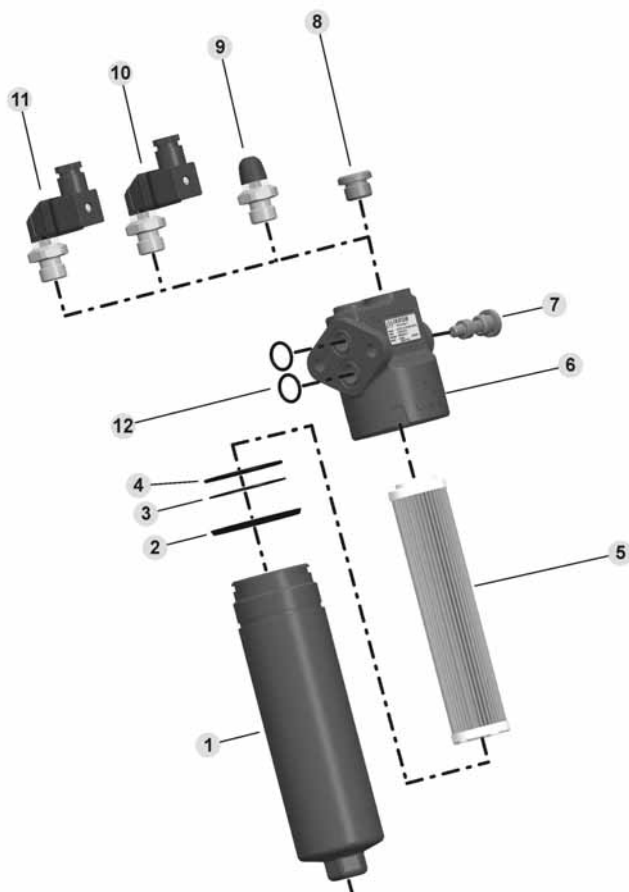

REPLACING ELEMENT

Once the working hours limit indicated in the maintenance instructions of the system is reached, or when the clogging indicators point out the limit pressure drop created inside the filter, the cartridge must be replaced, remembering that this procedure involves the drainage of hydraulic oil and therefore you need to prepare suitable containers to collect the oil.

Proceed as follows:

- A Stop the system in "Machine stopped" status.
- B Secure any shut-off valves on the hydraulic circuit.
- C Unscrew the filter container (pos.1).
- D Remove the clogged filtering cartridge (pos.5), making sure no residual particles have settled on the bottom (pos.1).
- E Make sure the seal, the O-ring (pos.2 - 4) and the anti-extrusion ring (pos.3) are not damaged, otherwise replace them and consequently position the new ones correctly.
- F Insert the new filtering cartridge, lubricating the sealing O-ring beforehand.
- G Screw the container tight (pos.1) making sure the threading is screwed correctly. Tighten to a tightening torque as indicated on pages 8, 9.
- H Start the machine for a few minutes.
- I Make sure there are no leaks.

Pos. Description

- | | |
|----|--|
| 1 | Filter bowl |
| 2 | Seal |
| 3 | Anti-extrusion ring |
| 4 | Sealing O-Ring |
| 5 | Filtering element |
| 6 | Filter head |
| 7 | By-pass valve |
| 8 | Sealing cap |
| 9 | Visual differential indicator |
| 10 | Visual electrical differential indicator |
| 11 | Visual electrical differential indicator with thermostat |
| 12 | Inlet and outlet ports' O-rings. |

When ordering spare parts, always specify the reference number, the filter code and quantity.

Example: Spare part pos. 4 - HHP41879 - Qty 2

HOW TO ORDER A COMPLETE FILTER

1

2

3

4

5

6

7

8

HF735 - 20.080 - AS - FG010 - LC - B6 - B - DD - G

1	Filter type	CODE
	See table page 8 and page 9	HF735-..

2	Filtering surface	CODE
	Standard	AS
	Multilayer	MS

3	Degree of filtration	CODE
	3 [µm] Micro-fibre glass	FG003
	6 [µm] Micro-fibre glass	FG006
	10 [µm] Micro-fibre glass	FG010
	25 [µm] Micro-fibre glass	FG025

4	Δp - Collapse pressure	CODE
	290 [psi]; (20 [bar])	LC
	3045 [psi]; (210 [bar])	HC

5	Valves	CODE
	By-pass setting 87 [psi] (6 [bar])	B60
	By-pass setting 87 [psi] (6 [bar]) and no return valve	B6N
	By-pass setting 87 [psi] (6 [bar]) and reverse flow valve	B6R
	Without	B00
	Without by-pass, with no return valve	B0N
	Without by-pass, with reverse flow	B0R

6	Seals	CODE
	Buna	B
	Viton	V

7	Indicator ports	CODE
	Without	XN
	Arranged	XA
	Arranged with plug	DD

8	Indicator	CODE
	Without	G
	Visual differential indicator	H
	Visual electrical differential indicator	U
	Visual electrical differential indicator with thermostat	W

03/10.2015

Standard
 On request

HOW TO ORDER A REPLACEMENT ELEMENT

1	2	3	4	5
HEK85	- 20.080	- AS	- FG010	- LC - B

1	Element type	CODE
	See table pag. 10	HEK85-..

2	Filtering surface	CODE
	Standard	AS
	Multilayer	MS

3	Degree of filtration	CODE
	3 [µm] Micro-fibre glass	FG003
	6 [µm] Micro-fibre glass	FG006
	10 [µm] Micro-fibre glass	FG010
	25 [µm] Micro-fibre glass	FG025

4	Δp collapse pressure	CODE
	290 [psi] (20 [bar])	LC
	3045 [psi] (210 [bar])	HC

5	Seals	CODE
	Buna	B
	Viton	V

Standard
 On request