

▼ Shown from left to right: RSM-1000, RSM-300, RSM-50, RCS-1002, RCS-302



## Maximum Power-to-Height Ratio



### Saddles

All RCS-Series cylinders have plunger mounting holes for installation of tilt saddles. See table for selection and dimensional information.

Page: **23**



### Low Clearance Lifting

The LW-16 Lifting Wedge and SOH-Series Machine Lifts are the perfect choice for lifting the first few millimeters.

Page: **172**

### RSM-series, Flat-Jac® Cylinders

- Compact, flat design for use where most other cylinders will not fit
- Single-acting, spring return
- RSM-750, 1000 and 1500 have handles for easy carrying
- Mounting holes permit easy fixturing
- Baked enamel finish for increased corrosion resistance
- CR-400 coupler and dust cap included on all models<sup>1)</sup>
- Hard chrome plated high quality steel plungers
- Grooved plunger ends require no saddle.

### RCS-series, Low-Height Cylinders

- Lightweight, low profile design for use in confined spaces
- Single-acting, spring return
- Baked enamel finish for increased corrosion resistance
- Plunger wiper reduces contamination, extending cylinder life
- CR-400 coupler and dust cap included on all models
- Grooved plunger end with threaded holes for mounting tilt saddles
- Integral handle on RCS-1002 for easy carrying
- Plated steel plungers.

▼ Only a couple of centimeters will do for an RSM-cylinder to lift a large construction.

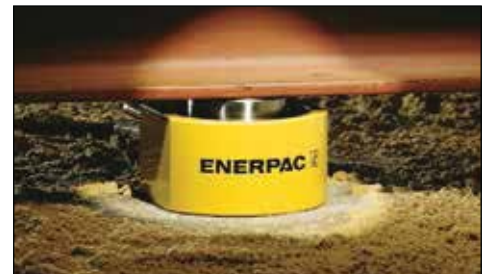

Cyl. Capacity	Stroke	Model Number	Cylinder Effective Area	Oil Capacity
ton (kN)	(mm)		(cm <sup>2</sup> )	(cm <sup>3</sup> )
5 (45)	6	RSM-50 <sup>1)</sup>	6,5	4
10 (101)	11	RSM-100 *	14,5	18
20 (201)	11	RSM-200 *	28,7	32
30 (295)	13	RSM-300 *	42,1	55
45 (435)	16	RSM-500 *	62,1	99
75 (718)	16	RSM-750	102,6	164
90 (887)	16	RSM-1000	126,7	203
150 (1386)	16	RSM-1500	198,1	317
10 (101)	38	RCS-101 *	14,5	55
20 (201)	45	RCS-201 *	28,7	129
30 (295)	62	RCS-302 *	42,1	261
45 (435)	60	RCS-502 *	62,1	373
90 (887)	57	RCS-1002 *	126,7	722

<sup>1)</sup> RSM-50 is fitted with an AR-400 coupler.

\* Available as set, see note on next page.

# Single-Acting, Low-Height Cylinders

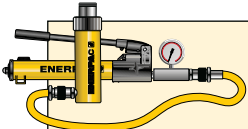

## Cylinder-Pump Sets

All cylinders marked with an \* are available as (cylinder, gauge, couplers, hose and pump) for your ordering convenience.

Page: **58**

## RSM, RCS Series



Capacity:

**5 - 150 ton**

Stroke:

**6 - 62 mm**

Maximum Operating Pressure:

**700 bar**

### Optional Bolt On Tilt Saddle Dimensions (mm)

For Cylinder Model:	Model Number	A	B	C*
RCS-101	CAT-11	35	11	21
RCS-201, -302, -502	CAT-51	50	15	29
RCS-1002	CAT-101	71	17	35

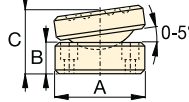

\* 'C' dimension equals saddle protrusion from plunger. Mounting screws are included.

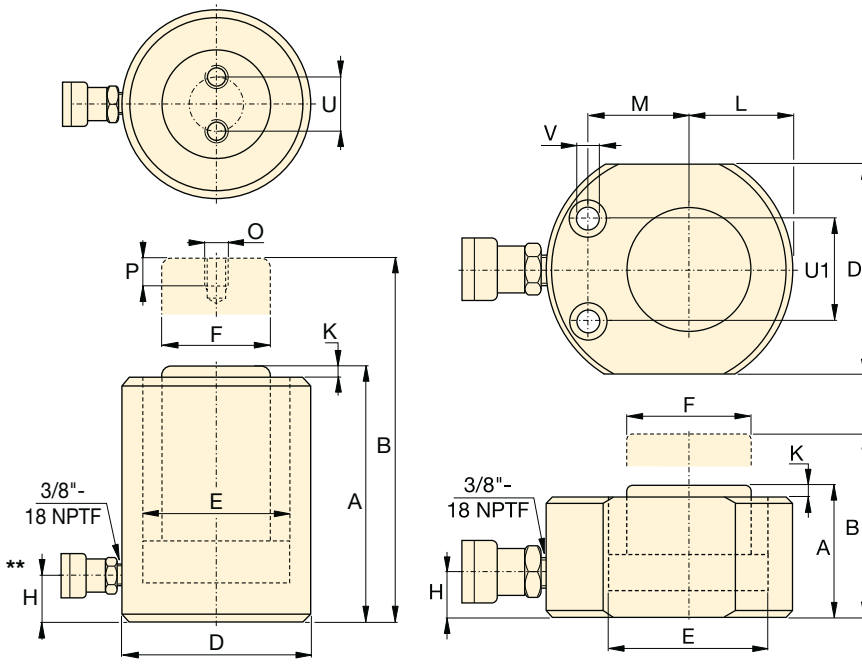

RCS-Series

RSM-Series



### Power Box

Tool box with hand pump, gauge adaptor assembly, hose and RSM or RCS-cylinders.

Page: **61**

### RSM Cylinder Mounting Hole Dimensions (mm)

Model Number	Bolt Circle U1	Hole Dia. V	Counter Bore Dia.	Counter Bore Depth
RSM-50	28,5	5,5	9,1	4,3
RSM-100	36,6	7,1	10,7	7,9
RSM-200	49,3	10,0	15,1	9,9
RSM-300	52,3	10,0	15,9	11,2
RSM-500	66,5	11,0	19,0	12,7
RSM-750	76,2	13,5	20,6	14,2
RSM-1000	76,2	13,5	20,6	14,2
RSM-1500	117,3	13,5	20,6	14,2

Collapsed Height	Extended Height	Outside Diameter	Cylinder Bore Dia.	Plunger Dia.	Base to Advance Port	Plunger Protrusion from Base	Plunger to Base	Plunger to Mtg. Hole	Thread	Thread Depth	Bolt Circle	Weight	Model Number
A (mm)	B (mm)	D (mm)	E (mm)	F (mm)	H (mm)	K (mm)	L (mm)	M (mm)	O (mm)	P (mm)	U (mm)	(kg)	
32	38	58 x 41	28,7	25,4	16	1	20	22	-	-	-	1,0	RSM-50 <sup>1)</sup>
43	54	82 x 55	42,9	38,1	19	1	27	34	-	-	-	1,4	RSM-100 *
51	62	101 x 76	60,5	50,8	19	1	39	39	-	-	-	3,1	RSM-200 *
58	71	117 x 95	73,2	63,4	19	2	47	44	-	-	-	4,5	RSM-300 *
66	82	140 x 114	88,9	69,8	19	2	57	53	-	-	-	6,8	RSM-500 *
79	95	165 x 139	114,3	82,6	19	2	69	66	-	-	-	11,3	RSM-750
85	101	178 x 153	127,0	92,2	19	2	76	74	-	-	-	14,5	RSM-1000
100	116	215 x 190	158,8	114,3	23	2	95	82	-	-	-	26,3	RSM-1500
88	126	69	42,9	38,1	17	5	-	-	M4	8	26	2,7	RCS-101 *
98	143	92	60,5	50,8	17	3	-	-	M5	8	40	5,0	RCS-201 *
117	179	101	73,2	66,5	19	3	-	-	M5	8	40	6,8	RCS-302 *
122	182	124	88,9	69,8	23	2	-	-	M5	8	40	10,0	RCS-502 *
141	198	165	127,0	92,2	31	1	-	-	M8	10	55	20,7	RCS-1002 *

\*\* 5° angle position of coupler on RCS-101, 201, 302.